

INSTRUCTIONS FOR THERMOWELD GROUNDING CONNECTIONS - BAR TO REBAR

BRE-3

Follow instructions on reverse side for proper use of copper shim stock or packing pad. Place bar and rebar into mold as shown.

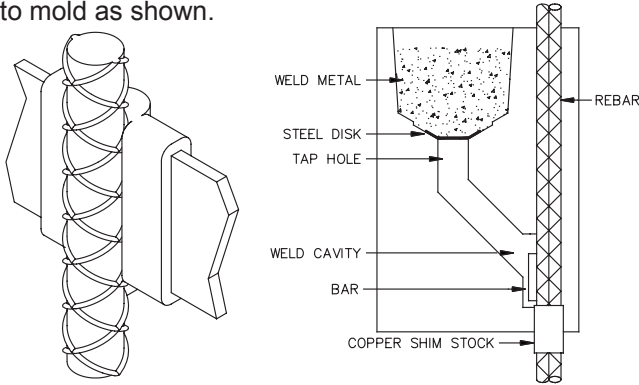

BRE-5

Follow instructions on reverse side for proper use of copper shim stock or packing pad. Butt end of bus or lug against rebar.

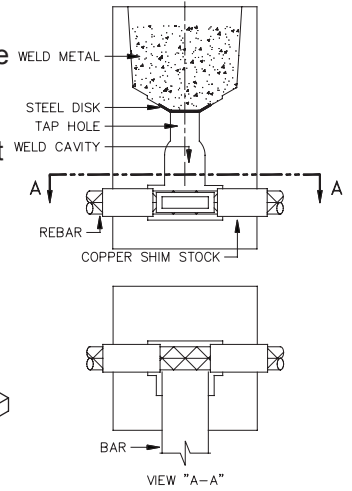
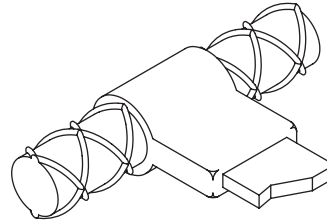

BRE-6

Follow instructions on reverse side for proper use of copper shim stock or packing pad. Place bus bar and rebar into mold as shown.

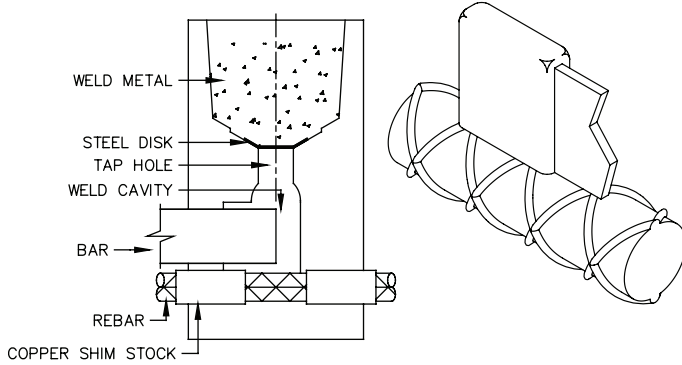

BRE-8

Follow instructions on reverse side for proper use of copper shim stock or packing pad. Place bus bar and rebar into mold.

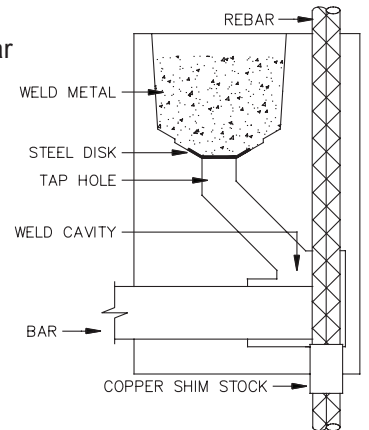
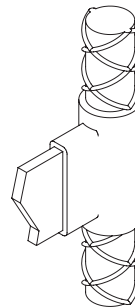

BRE-20

Follow instructions on reverse side for proper use of copper shim stock or packing pad. Place bus bar and rebar into mold.

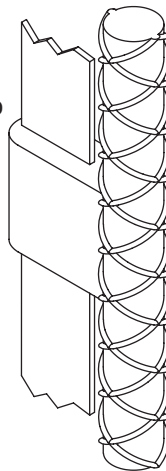
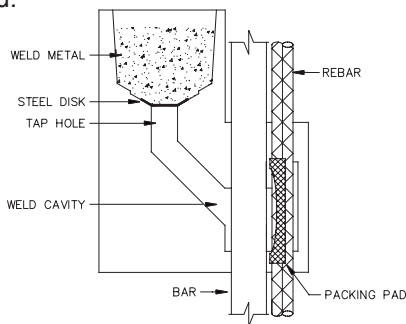

GENERAL SAFETY INSTRUCTIONS

1. Always wear proper clothing, safety glasses and gloves when exothermic welding.
2. Only weld items mold is designed for.
3. Do not use worn or broken molds which could cause leakage of molten weld metal.
4. Make sure that the material being welded fits in the mold properly and that the mold will close tightly around them.
5. Do not alter molds or accessories without factory authorization.
6. Avoid breathing concentrations of smoke, as it may be hazardous to your health.
7. Avoid contact with hot materials.
8. Remove or protect fire hazards in the welding area.
9. Avoid moisture and contaminants in the mold and materials being welded. Contact of molten weld metal with moisture or contaminants may cause weld metal to spew out of mold.
10. When welding to pipe or vessels, you should consider the following:
 - a. the effect welding may have on structural members and thin wall pipe or vessels.
 - b. pipe or vessels that are pressurized or contain (or have contained) flammable, explosive or hazardous materials should be evaluated in the case of a melt-through or hot molten weld metal coming in contact with any flammable, explosive or hazardous materials.
11. Failure to abide by the above and follow welding procedures may result in improper welds, damage to the material being welded or create hazardous situations for the individual.

PREPARATION OF BUS BAR, LUGS & COPPER STRIP

1. Bus bar and lugs must be bright, clean and dry on all surfaces that are within the weld area in the mold.
2. Use a file or card cloth brush to remove oxides.

PREPARATION OF REINFORCING BAR

NOTE: *The use of ThermOweld exothermic connections on rebar can have an effect on the rebar's structural strength. Consideration as to weld location should be made before actual welding. Area under minimum stress is preferred.*

1. Surface to be welded must be bright, clean and dry.
2. Remove rust and mill scale with coarse file or grinder.
3. Remove oil, grease or pitch coatings with solvent or torch.

USING COPPER SHIM STOCK AND PACKING PAD

1. For molds requiring copper shim stock, wrap one copper shim tightly around rebar on each side of area to be welded.
2. For molds requiring packing pad, form pad to rebar with hole running lengthwise over cleaned area of rebar. Press mold over pad with ends of pad even with edges of the mold. Secure backing plate when required.

WELDING PROCEDURE

1. Check mold tag for material to be welded and proper cartridge size to use.
2. Make sure all surfaces and conductors are clean, dry and are the proper sizes for the molds application per mold tag.
3. Molds can be dried by heating to approximately 250°F. Molds may be dried with a hand operated butane torch or by firing a charge in the mold before making the desired weld.
4. Position mold onto conductor(s). See front of this sheet for positioning of conductors into mold. Lock mold with handle clamps or frame, whichever is the case.
5. Insert steel disk being sure it is directly centered over the tap hole. Failure to insert disk into mold or failure to seat the disk properly can create an improper weld and may cause mold to spew weld metal.
6. Pour proper weld cartridge(s) into crucible being careful not to loosen all the starting powder while pouring weld metal into mold. Use of wrong weld cartridge can cause improper welds or damage to molds.
7. Close the lid of the mold and place a small amount of starting powder in the ignition pocket.
OR
Insert the EZ Lite® ignitor in the connector of thermOweld EZ Lite Remote™ Unit. Close the lid and place the ignitor in the top opening of the EZ Lite® Lid allowing the connector to rest on the lid.
8. Before igniting, verify conductor positioning and that mold is closed completely.
9. Ignite the starting powder with the flint ignitor. Pull flint ignitor away from starting powder right after trigger is pulled to keep from fouling flint ignitor. (Do not place any exposed body part directly over lid or in front of lid opening.)
OR
Turn the power button to the "ON" position on the EZ Lite Remote™ Unit followed by the "operate" button until the exothermic reaction is initiated.
10. Wait for 15 seconds before opening mold to allow weld metal to cool.
11. To clean the mold, use a natural bristle brush, soft cloth or newspaper before making next weld. On horizontally split molds, use a small diameter rod or screw driver to remove slag from tap hole. Caution should be used when cleaning molds to avoid burns from contact with hot mold.

DO NOT USE WIRE BRUSH TO CLEAN MOLD!

- NOTE:**
1. A fouled flint ignitor may be cleaned by soaking in house hold ammonia.
 2. Proper cartridge size is marked on mold tag and shown on the bottom of the cartridge tube.
 3. Cartridge size is the approximate weight of the powder in grams. When the cartridge size specified is not available, two or more smaller cartridges or part of a larger cartridge may be used. Care should be taken not to mix starting material in-between cartridges.
 4. Handle Clamp adjustments may be made by removing cotter pin and clevis pin and turning eye bolt one turn clockwise to tighten or one turn counter clockwise to loosen.

